

This Page Is Inserted by IFW Operations
and is not a part of the Official Record

BEST AVAILABLE IMAGES

Defective images within this document are accurate representations of the original documents submitted by the applicant.

Defects in the images may include (but are not limited to):

- BLACK BORDERS
- TEXT CUT OFF AT TOP, BOTTOM OR SIDES
- FADED TEXT
- ILLEGIBLE TEXT
- SKEWED/SLANTED IMAGES
- COLORED PHOTOS
- BLACK OR VERY BLACK AND WHITE DARK PHOTOS
- GRAY SCALE DOCUMENTS

IMAGES ARE BEST AVAILABLE COPY.

**As rescanning documents *will not* correct images,
please do not report the images to the
Image Problem Mailbox.**



INTERNATIONAL APPLICATION PUBLISHED UNDER THE PATENT COOPERATION TREATY (PCT)

<p>(51) International Patent Classification ⁶ : E21B 33/14, 43/30, 33/127, 43/10</p>	<p>A2</p>	<p>(11) International Publication Number: WO 98/09053 (43) International Publication Date: 5 March 1998 (05.03.98)</p>
<p>(21) International Application Number: PCT/US97/15275 (22) International Filing Date: 29 August 1997 (29.08.97) (30) Priority Data: 60/025,139 30 August 1996 (30.08.96) US (71) Applicant: BAKER HUGHES INCORPORATED (US/US); 3900 Essex Lane, Houston, TX 77027 (US). (72) Inventors: MURRAY, Douglas, J.; 5922 Cutross Close, Humble, TX 77346 (US). SMITH, Robert, C.; 23 Elmfield Avenue, Aberdeen (GB). MYRON, Walter, J.; 23 McDonald Drive, Ellon, Aberdeenshire AB41 8BD (GB). JOHNSON, John, J.; 4027 Markley, Houston, TX 77087 (US). HIRTH, David, E.; 4306 Argentina, Pasadena, TX 77504 (US). SMITH, Sidney, K.; 1406 Axleridge, Conroe, TX 77384 (US). WEAVER, Chris; 5727 Georgetown Colony Drive, Houston, TX 77084 (US). (74) Agent: MURPHY, Keith, J.; Fishman, Dionne, Cantor & Colburn, 88 Day Hill Road, Windsor, CT 06095 (US).</p>		<p>(81) Designated States: AU, CA, GB, NO. Published <i>Without international search report and to be republished upon receipt of that report.</i></p>

(54) Title: METHOD AND APPARATUS FOR SEALING A JUNCTION ON A MULTILATERAL WELL

(57) Abstract

Methods and apparatus for forming multilateral wells and sealing the junction between the main well bore and a lateral well. In a first embodiment of the invention, a main well bore liner includes windows or openings formed in the liner. A drillable insert is positioned near the window for support when the lateral well is drilled. The window is also filled with a drillable material. A second embodiment of the invention uses inflatable casing packers which are inflated with cement to form junction having pressure integrity from the inside and the outside with a full opening lateral and a main bore restricted only by the inner diameter of the inflatable casing packers. A third embodiment of the invention uses a layered sealing sleeve at the opening of the lateral well. A tie back liner top mandrel is wedged through an opening in the layered sealing sleeve. The mandrel includes a flange, at the top and the interference fit between the flange and the opening in the sealing sleeve forms a hydraulic seal between the main well bore and the lateral well.

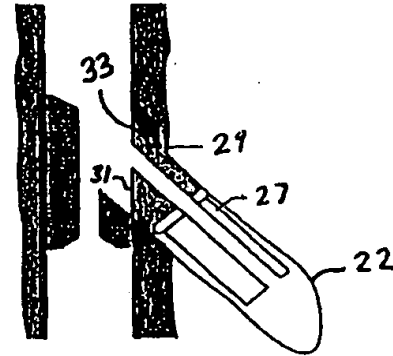

FOR THE PURPOSES OF INFORMATION ONLY

Codes used to identify States party to the PCT on the front pages of pamphlets publishing international applications under the PCT.

AL	Albania	ES	Spain	LS	Lesotho	SI	Slovenia
AM	Armenia	FI	Finland	LT	Lithuania	SK	Slovakia
AT	Austria	FR	France	LU	Luxembourg	SN	Senegal
AU	Australia	GA	Gabon	LV	Latvia	SS	Swaziland
AZ	Azerbaijan	GB	United Kingdom	MC	Monaco	TD	Chad
BA	Bosnia and Herzegovina	GE	Georgia	MD	Republic of Moldova	TG	Togo
BB	Barbados	GH	Ghana	MG	Madagascar	TJ	Tajikistan
BE	Belgium	GN	Guinea	MK	The former Yugoslav Republic of Macedonia	TM	Turkmenistan
BF	Burkina Faso	GR	Greece	NL	Netherlands	TR	Turkey
BG	Bulgaria	HU	Hungary	ML	Mali	TT	Trinidad and Tobago
BJ	Benin	IE	Ireland	MN	Mongolia	UA	Ukraine
BR	Brazil	IL	Israel	MR	Mauritania	UG	Uganda
BY	Belarus	IS	Iceland	MW	Malawi	US	United States of America
CA	Canada	IT	Italy	MX	Mexico	UZ	Uzbekistan
CF	Central African Republic	JP	Japan	NE	Niger	VN	Viet Nam
CG	Congo	KE	Kenya	NL	Netherlands	YU	Yugoslavia
CH	Switzerland	KG	Kyrgyzstan	NO	Norway	ZW	Zimbabwe
CI	Côte d'Ivoire	KP	Democratic People's Republic of Korea	NZ	New Zealand		
CM	Cameroon	KR	Republic of Korea	PL	Poland		
CN	China	KZ	Kazakhstan	PT	Portugal		
CU	Cuba	LC	Saint Lucia	RO	Romania		
CZ	Czech Republic	LI	Liechtenstein	RU	Russian Federation		
DE	Germany	LK	Sri Lanka	SD	Sudan		
DK	Denmark	LR	Liberia	SE	Sweden		
EE	Estonia			SG	Singapore		

METHOD AND APPARATUS FOR SEALING A JUNCTION ON A MULTILATERAL WELL.**Background of the Invention****Field of the Invention**

The invention relates generally to well drilling and in particular to methods and apparatus for forming lateral wells and sealing the junctions between multi-lateral wells and a main well bore.

5

Prior Art

Horizontal well drilling and production have been increasingly important to the oil industry in recent years. While horizontal wells have been known for many years, only relatively recently have such wells been determined to be a cost effective alternative (or at least companion) to conventional vertical well drilling. Although drilling a horizontal well costs substantially more than its vertical counterpart, a horizontal well frequently improves production by a factor of five, ten, or even twenty in naturally fractured reservoirs. Generally, projected productivity from a horizontal well must triple that of a vertical hole for horizontal drilling to be economical. This increased production minimizes the number of platforms, cutting investment and

10

15

operational costs. Horizontal drilling makes reservoirs in urban areas, permafrost zones and deep offshore waters more accessible. Other applications for horizontal wells include periphery wells, thin reservoirs that would require too many vertical wells, and reservoirs with coning problems in which a horizontal well could be optimally
5 distanced from the fluid contact.

As a result of the foregoing increased dependence on and importance of horizontal wells, horizontal well completion, and particularly multilateral well completion have been important concerns and have provided (and continue to provide) a host of difficult problems to overcome. Lateral completion, particularly at the
10 juncture between the vertical and lateral well bore is extremely important in order to avoid collapse of the well in unconsolidated or weakly consolidated formations. Thus, open hole completions are limited to competent rock formations; and even then open hole completion are inadequate since there is no control or ability to re-access (or re-enter the lateral) or to isolate production zones within the well. Coupled with this need
15 to complete lateral wells is the growing desire to maintain the size of the wellbore in the lateral well as close as possible to the size of the primary vertical wellbore for ease of drilling and completion.

Notwithstanding a variety of attempts at obtaining cost effective and workable lateral well completions, there continues to be a need for new and improved methods and devices for providing such completions, particularly sealing between the juncture
20 of vertical and lateral wells, particularly in multilateral systems.

Summary of the Invention:

The above-discussed and other drawbacks and deficiencies of the prior art are overcome or alleviated by the methods and devices of the present invention for sealing
25 the junctions between a main well bore and lateral wells. A first embodiment for forming lateral wells is a top down system in which the lateral wells are formed from the top of the main well bore to the bottom of the main well bore. The initial liner string includes drillable inserts and side windows that facilitate formation of the lateral

wells. The drillable inserts are made from a drillable material and the side windows are filled with a drillable material which eliminates the need for metal milling.

5 A second embodiment for sealing a junction between a main well bore and a lateral well includes running a first inflatable casing packer in the lateral well and filling the mandrel in the lateral well with a hardening material. A portion of the first inflatable casing packer is removed from the main well bore and a second inflatable casing packer is run in the main well bore. The hardening material in the lateral well provides support at the portion of the second inflatable casing packer positioned at the lateral well opening. The hardening material in the lateral well may then be removed.

10 A third embodiment of sealing the junction between a lateral well and a main well bore uses a flexible sealing sleeve. The liner placed in the main well bore includes windows for creating lateral wells. The windows are filled with a drillable material to reduce the amount of metal milling. Once the lateral well is drilled, a flexible sealing sleeve having a seal opening is aligned with the entrance to the lateral well. A mandrel with a flange at the top is run through the seal opening and a flange support sleeve presses the flange of the mandrel against the seal. The outer diameter of the mandrel may be greater than the inner diameter of the seal opening thereby creating a tight seal between the sealing sleeve and the mandrel. Positioning the sealing sleeve after the lateral well is drilled prevents the seals from being damaged during lateral operations.

15 20 The above-discussed and other features and advantages of the present invention will be appreciated and understood by those skilled in the art from the following detailed description and drawings.

Brief Description of the Drawings

25 Referring now to the drawings wherein like elements are numbered alike in the several FIGURES:

FIGURE 1 is a cross sectional view of a portion of the liner including a side pocket window;

FIGURE 2 is a cross sectional view illustrating a lateral well being drilled;

FIGURE 3 is a cross sectional view illustrating completion of the lateral well

FIGURE 4 is a cross sectional view illustrating completion of the main well bore;

5 FIGURES 5A-5B are cross sectional views of the portion of the liner including a side pocket window;

FIGURE 6 is a cross sectional view taken along line 6-6 of FIGURE 5A;

FIGURE 7 is a cross sectional view taken along line 7-7 of FIGURE 5B;

FIGURES 8A-8B are cross sectional views of the liner having a first type of lateral well completion;

10 FIGURES 9A-9B are cross sectional views of the liner having a second type of lateral well completion;

FIGURES 10A-10B are cross sectional views of the liner of FIGURES 8A-8B having the drillable insert removed;

15 FIGURES 11A-11B are cross sectional views of the liner of FIGURES 9A-9B having the drillable insert removed;

FIGURES 12-17 are cross-sectional diagrams illustrating a second embodiment for creating a sealed junction between main and lateral wells;

FIGURES 18-22 are cross-sectional diagrams illustrating a third embodiment for sealing a junction between a main well and a lateral well; and

20 FIGURE 23 is an exploded view of the sealing sleeve.

Detailed Description of the Invention

25 FIGURE 1 is a cross sectional view of a portion of the liner for establishing a lateral well. The liner 10 includes an opening or window 12 formed in the side of the liner 10. Within the liner 10 is a drillable insert 14, made from a drillable material, which is rotationally locked to the liner 10. The window 12 is also filled with a drillable material. In an exemplary embodiment, the drillable material is concrete. The use of a drillable material, such as concrete, eliminates the need for metal milling and reduces risk of tools becoming stuck in debris. In addition, no plastics or composites

are used in the liner 10 due to the fact that plastics and composites can have a finite life when left in the well. The drillable insert 14 must withstand the torque and set down weight required to drill the lateral well 22 (shown in FIGURE 2) and provide additional bending and torsional strength to the window joint while running. FIGURES 5A-5B
5 are cross sectional diagrams of the liner 10 including the window 12. As shown in FIGURES 6 and 7, which are cross sectional views taken along lines 6-6 of FIGURE 5A and 7-7 of FIGURE 5B respectively, the main through bore is drilled at an offset from the center, to maximize the thickness of the liner 10 near the window 12.

An inflatable packer 16, including regular inflation valves, is provided along the
10 outside of the window 12. A work string 2 is shown positioned within the liner 10. The window 12 is formed at an angle relative to the main axis of the liner and includes an uphole surface 122 and a downhole surface 124. The uphole surface 122 and the downhole surface 124 are generally parallel and both surfaces are at an oblique angle relative to the central axis of the liner 10. The window 12 is machined in place at
15 the appropriate angle, to match drilling techniques (e.g. typically 2-3° from the central axis).

The liner 10, with as many liner windows 12 as needed, is run in, oriented, and cemented in place using known techniques. Cementing of the liner 10 is done with inner string as is known in the art. A system is needed to orient the window 12, before
20 cementing, and then verify the window 12 orientation after cementing. Once the liner 10 is cemented in place, the inflatable packer 16 is then inflated using a hardening material (e.g. preferably expanding cement). The cement inflated packer 16 will give additional support to the liner 10 and the formation at the window 12. The method of completing a full bore, full access, junction in a multi-lateral well will now be
25 described.

As shown in FIGURE 2, a standard type of mud motor drilling bottom hole assembly (BHA) 20 is run in, until it reaches the first liner window 12. The drill face is then oriented in the direction of the window 12, using measurement-while-drilling (MWD) as a reference. The insert 14 and the inflated packer 16 are then drilled using a

standard technique referred to as time drilling. The drill need only pass through the drillable insert 14, the drillable material in the window 12 and the rubber and cement in the inflatable packer 16. This eliminates metal milling which can cause tools to become stuck and leave debris in the well. The drill removes a portion of the insert 14 and tracks out through the window 12, creating the lateral well 22. Drilling can continue for as long as necessary. Typically, a short section of the lateral well 22 is drilled (e.g. around 200-300 ft.). Once the lateral well 22 is begun, a drilling liner is positioned in the lateral well 22. A lower portion 26 of the drillable insert 14 below the liner window 12 acts as a guidestock as extra trips to the lateral well 22 are made.

As shown in FIGURE 3, once the lateral well 22 has been started, a drilling liner 27 with a packer 29 is run to the lateral well 22. The upper section of liner 27 includes a running tool and the packer 29 is oriented using MWD, in conjunction with a built-in orienting lug on the running tool. The lateral packer 29 has a packing element that is cut on a double helix so that the angle of the packer 29 matches the angle of the window 12. The packer 29 has slips 33 placed around the circumference. The top 31 of the lateral packer 29 is also cut on a double helix so that when the packer 29 is installed, there will be no part of the packer 29 extending in the main bore of the liner 10. When the packer 29 is lined up with the window 12, the element and slips 33 are set in a known manner (e.g. by a hydraulic piston). FIGURES 9A-9B are cross-sectional views of the wellbore fitted with a mechanical lateral packer 29. The lateral liner packer 29 locks in place, and will not be disturbed by the drilling BHA.

The main part of the lateral well can now be drilled, still using the portion of the drillable insert 26 as a guidestock to divert the drilling BHA into the lateral well 22. The window 12 should be able to withstand drilling of the length of the lateral well (e.g. 10,000 feet). The lateral well can now be completed using standard techniques or equipment. The junction between the lateral liner and the drilling liner is sealed using standard liner hanger and packer technology.

An alternative to using a packing element and slips 33 is to use an inflatable packing element. FIGURES 8A-8B are cross-sectional views of the wellbore fitted

-7-

with an inflatable lateral packer 29'. This would increase the flexibility in the positioning of the packer 29'. The inflatable element could be 10-20 feet long, so that it would also pack off in the open hole.

5 The installation of the liner for the lateral well 22 may be performed in two ways. The lateral well liner can be run as one piece, or in two or more pieces. The liner in the lateral well may be a short section that is used just to seal off the junction between the lateral well and the liner 10. Then a second smaller diameter liner is run for the rest of the lateral well, similar to a standard liner completion. Alternatively, the lower part of the liner could be run first, then be tied back to the liner window joint, 10 using seals such as a PBR or a casing patch.

As shown in FIGURE 4, after the lateral well 22 is fully drilled and lined, the drilling BHA 20 is run in and by orienting the drill face away from the window 12 the remainder of the drillable insert 14 is removed. The joint between the lateral well 22 and the liner 10 does not extend into the inner diameter of the liner and thus does not 15 cause any restriction in the inner diameter of the vertical well, making the method of the present invention ideal for dual completions and intelligent completions. FIGURES 10A-10B are cross sectional views of the liner shown in FIGURES 8A-8B with the drillable insert 14 removed. FIGURES 11A-11B are cross-sectional views of the liner shown in FIGURES 9A-9B with the drillable insert 14 removed. Without having to 20 remove the drilling BHA 20, the drill can be run in to the next window joint, and the next lateral is created. If further laterals are needed the same drilling BHA can be run down either to the next window or to the original liner shoe track for the lowest lateral.

There are advantages gained from drilling the laterals from the top down. If something goes wrong when drilling a lower lateral, there is very little below this point 25 that can be lost. When drilling laterals from the bottom up, a lot of time and cost can be lost if something goes wrong.

FIGURES 12-17 illustrate an alternative method for creating sealed multilateral junctions down hole using inflatable casing packers. As shown in FIGURE 12, the first step is to form the main well bore 100 and place a liner 102 in the main well bore 100

-8-

using conventional techniques. An orienting packer 104 is placed in the main well bore 100 and a whipstock 106 is placed in the main well bore 100. A lateral well 120 is then drilled using conventional techniques (e.g. mills, drills, etc.).

As shown in FIGURE 13, the whipstock 106 that was used to drill the lateral well 120 is then retrieved and replaced with a whipstock 122 that is designed to be washed over easily, yet still maintain a close fit to the casing inner diameter.

Whipstock 122 may have a steel core and composite outer shell to provide for easy washover. Next, a liner 124 is run into the lateral well 120, with an inflatable casing packer 126 at the top. The inflatable casing packer 126 is positioned so that it

completely covers the window junction between the main well bore 100 and the lateral well 120 and overlaps into both the main bore 100 and the lateral bore 120. The inflatable casing packer 126 is then inflated with a material that will harden into a solid keeping the element energized (e.g. concrete). The washover whipstock 122 supports the portion of the liner 124 and the inflatable casing packer 126 in the main bore 100

when the inflatable casing packer 126 is inflated. In situations where a second inflatable casing packer 140 is to be run in the main well bore 100 (shown in FIGURE 15), the mandrel of the first inflatable casing packer 126 can then be filled with a material 128 that will harden into a drillable solid (e.g. cement). The material 128 will provide support for the second inflatable casing packer 140 that will be positioned in the main well bore 100. A plugging device 130 can be placed in the lower part of the mandrel. In an alternative embodiment, the mandrel for the lateral well 120 could be run in the well with a drillable material already placed in the inner diameter of the mandrel.

After the inflatable casing packer 126 and fill media 128, if used, have hardened, the portion of the inflatable casing packer 126 in the main well bore 100 and the washover whipstock 122 can be removed from the well as shown in FIGURE 14. The well bore 100, at the junction between the main well bore 100 and the lateral well 120, will now resemble a smooth main bore. This junction can be pressured tested and in some cases may provide an adequate sealed junction. If the lateral well bore 120 is

left open and the pressure integrity of the junction is deemed suitable the junction could be considered complete. This leaves a full opening inner diameter in both the main bore 100 and the lateral bore 120.

5 If the junction does not pass the pressure test, a packer and plugs can be run to straddle the junction and a squeeze job can be performed. The junction can then be drilled back out. If the junction still does not test, or a better seal is desired, an additional inflatable casing packer 140, shown in FIGURE 15, can then be run down the main bore 100 and placed across the junction, overlapping both sides of the lateral well 120. The second inflatable casing packer mandrel 142 can have a retrievable whipstock 144 already in place that will locate in the orientation packer 104 originally used to mill the lateral well 120. The whipstock 144 is positioned to align a mill with the lateral well bore 120. The packer 140 is then inflated with a material that will harden into a solid that will keep the element energized (e.g. cement). As shown in FIGURE 16, a mill is used to remove the hardened material 128 in the lateral well 120. As shown in FIGURE 17, the whipstock 144 is retrieved from the main well bore 100. The result is a junction between the main well bore 100 and the lateral well 120 that has pressure integrity from the inside and the outside with a full opening lateral and main bore restricted only by the inner diameter of the inflatable casing packers.

10 15 20 25 FIGURES 18-22 are cross-sectional diagrams illustrating a third embodiment for sealing a junction between a main well and a lateral. As shown in FIGURE 18, the main well 300 includes a liner 302 including a window 304 formed in the side of the liner 302. The pre-milled window 304 is covered with a composite, drillable material 306 located on the outside of and within the window 304. A protection sleeve 308 is positioned on the inside of the liner 203 to protect the window 304 during run in. An inner work string 310 is then run to bottom and is used to cement the liner 302 in place. As the work string 310 is removed, the inner protection sleeve 308 is also pulled from the main well bore.

After the protection sleeve 308 is retrieved, a whipstock 320 is set in the main well 300 and the lateral well 322 is drilled as shown in FIGURE 19. The presence of

-10-

the pre-milled window 304 and the composite outer covering 306 will insure a negligible amount of metal debris and a perfectly shaped window.

As shown in FIGURE 20, once the lateral well 322 is drilled, the whipstock 320 is replaced with a guidestock 330 and the lateral liner 332 can be run and cemented as desired. At this time, a layered sealing sleeve 334 is run in the main well bore 300. Only after the lateral well 322 has been drilled is the layered sealing sleeve 334 run in the well and placed across the window. This prevents the sealing sleeves from becoming damaged during lateral operations. The sealing sleeve can also be modified for particular conditions in the well. The layered sealing sleeve 334 includes an opening 336 for alignment with the lateral well 322. The layered sealing sleeve 334 slides around the guidestock 330 and is oriented so that the sealing sleeve opening is aligned with the lateral well 322. The guidestock 330 can be removed when needed without affecting the sealing sleeve 334. The details of the construction of the layered sealing sleeve 334 are described below with reference to FIGURE 23.

With the sealing sleeve 334 in place, a variety of systems can be used to pass through the sealing sleeve 334 and into the lateral liner 332. As shown in FIGURE 21, a tie back liner top mandrel 340 having a flange 342, for example, can be pierced through the sealing sleeve 334 and into the lateral liner 332. The interference fit between the flange 342 and the sealing sleeve 334 form a hydraulic seal between the main well bore and the lateral well 322. In addition, the outer diameter of the mandrel 340 may be greater than the sealing sleeve opening 336 so that a tight fit is achieved between the mandrel 340 and the sealing sleeve 334. As the mandrel 340 passes through the opening 336 in the sealing sleeve 334, a pressure tight seal will result. A flange support sleeve 344 is insert in the main well bore and presses the flange 342 against the sealing sleeve 334. The pressure isolation across the junction between the main well bore and the lateral well allows this type of multi-lateral completion to be run in zones currently not suitable for current multi-lateral systems.

FIGURE 22 is a cross sectional view of an alternative device for completing the lateral well 322. An isolating sleeve 400 is run in the main well bore. The isolating

sleeve 400 includes a lower lip 410 which is aligned with the bottom of the sealing sleeve opening and an upper lip 412 that extends beyond the top of the opening in the sealing sleeve. The isolating sleeve is held in place using packers 402. A mandrel 404 is then run through the isolating sleeve 400 and into the later well liner 332.

5 FIGURE 23 is an exploded view of the sealing sleeve 334. The sealing sleeve includes an inner sleeve 500 which has an opening 504 formed therein. A recess 502 is formed in the inner sleeve 500 near the opening 504 to accept sealing layers 506 and 510. The inner sleeve 500 is not intended to contact the mandrel passing through the sealing sleeve 334. A first sealing layer 506 is placed in the recess 502. In an
10 exemplary embodiment, the first sealing layer is made from a soft metal (e.g. lead, brass). The first seal layer 506 is saddle shaped, includes an opening 508 and acts as a wiper contacting the mandrel and giving support for external pressure. A second sealing layer 510 is saddle shaped and placed over the first sealing layer 506. The
15 second sealing layer 510 has an opening 512. The second sealing layer is made from a resilient material (e.g. rubber, Teflon) and acts as a main seal having a greater interference with the mandrel. The final layer is a full cylinder 514 with an opening 516. The final layer 514 is made from a steel and has little or no interference with the mandrel. The final layer 514 acts as a back up for sealing against internal pressure.

20 While preferred embodiments have been shown and described, various modifications and substitutions may be made thereto without departing from the spirit and scope of the invention. Accordingly, it is to be understood that the present invention has been described by way of illustration and not limitation.

What is claimed is:

CLAIM 1. A method for sealing a junction between a primary wellbore and a lateral wellbore comprising:

- a) running a casing packer into a lateral wellbore while leaving part of the casing packer in the primary wellbore;
- 5 b) inflating said packer with a hardenable material to create a hardened tube to seal the junction;
- c) milling out to reopen said primary wellbore.

CLAIM 2. A method for sealing a junction between a primary wellbore and a lateral wellbore as claimed in claim 1 wherein said material is selected from the group consisting of cement and epoxy.

CLAIM 3. A method for sealing a junction between a primary wellbore and a lateral wellbore comprising:

- a) running a casing packer into a lateral wellbore while leaving part of the casing packer in the primary wellbore;
- 5 b) inflating said packer with a hardenable material to create a hardened tube to seal the junction;
- c) filling a lumen of said packer with hardenable fluid;
- d) milling out to reopen said primary;
- e) removing a preinstalled whipstock;
- 10 f) installing a washover whipstock and a second casing packer, said second casing packer being installed in said primary wellbore and bridging said lateral wellbore;
- g) inflating said second casing packer with hardenable material;
- h) milling said lumen of said lateral;
- 15 i) removing said washover whipstock whereby a sealed junction is completed.

CLAIM 4. A method for sealing a junction between a primary wellbore and a lateral wellbore as claimed in claim 3 wherein said hardenable material is one of cement and epoxy.

CLAIM 5. A method for creating a sealed junction between a primary wellbore and a lateral wellbore comprising:

- a) running a casing segment having a premachined window at a predetermined angle and filled with a drillable material said segment further including and insert of a drillable material adjacent said window;
- b) drilling through said drillable material in said insert and in said window to open said window;
- c) installing a liner and sealing said liner to said primary wellbore;
- d) milling said primary wellbore to remove remnants of said insert.

CLAIM 6. A method for creating a sealed junction between a primary wellbore and a lateral wellbore as claimed in claim 5 wherein said premachined window is at an angle of about 2° - 3° from the primary wellbore axis.

CLAIM 7. A method for creating a sealed junction between a primary wellbore and a lateral wellbore as claimed in claim 5 wherein said primary wellbore includes a through bore which is radially offset within a liner in the primary wellbore.

CLAIM 8. A method for sealing the junction between a lateral and primary wellbore comprising:

- 5 a) providing a casing segment having a pre-installed window, said window being covered with a drillable, fluid impermeable material said segment further including a protection sleeve removably mounted on an inner diameter of said segment;
- b) running said casing segment in the hole;
- c) cementing said segment in the hole and removing said protection sleeve;
- d) setting a whipstock and running a drill string through said material;
- 10 e) installing a layered sealing sleeve over said window at the ID of the primary wellbore;
- f) installing a liner retainer having a flange;
- g) running a seal sleeve to bear against said flange to seal the lateral liner to the primary wellbore.

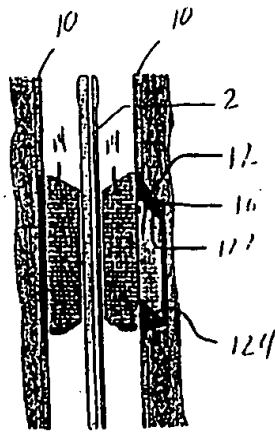

FIG. 1

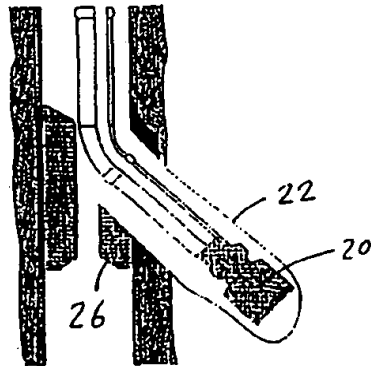

FIG. 2

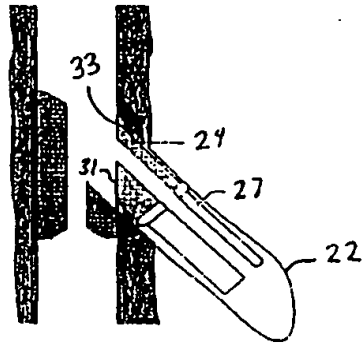

FIG. 3

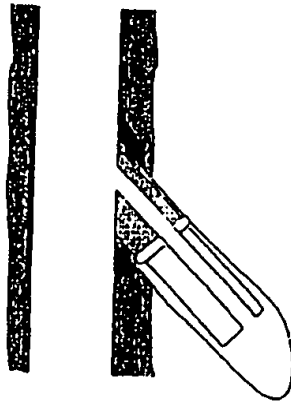

FIG. 4

3/20

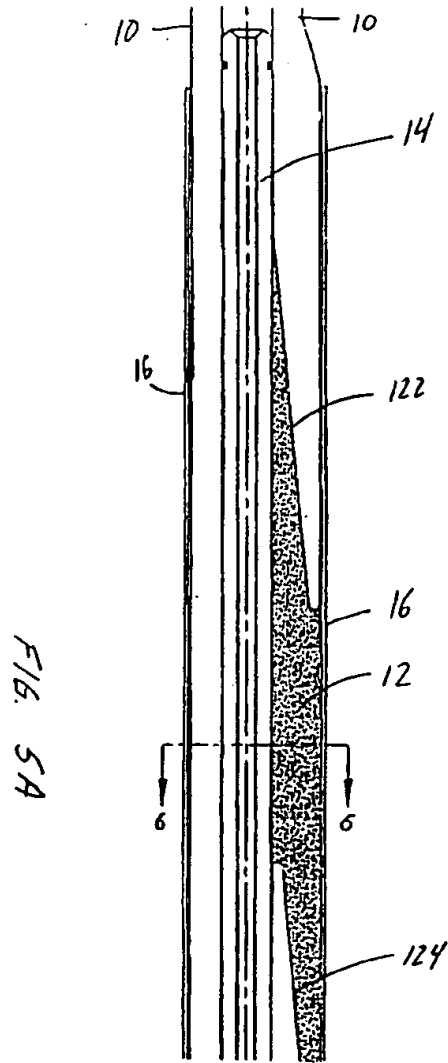

Fig. 7

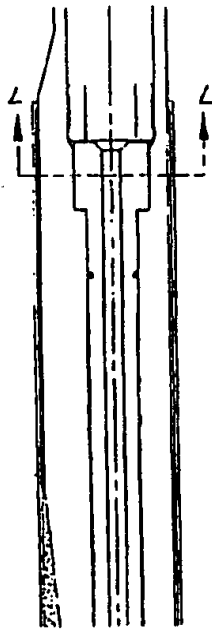
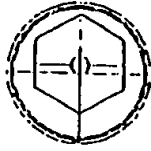
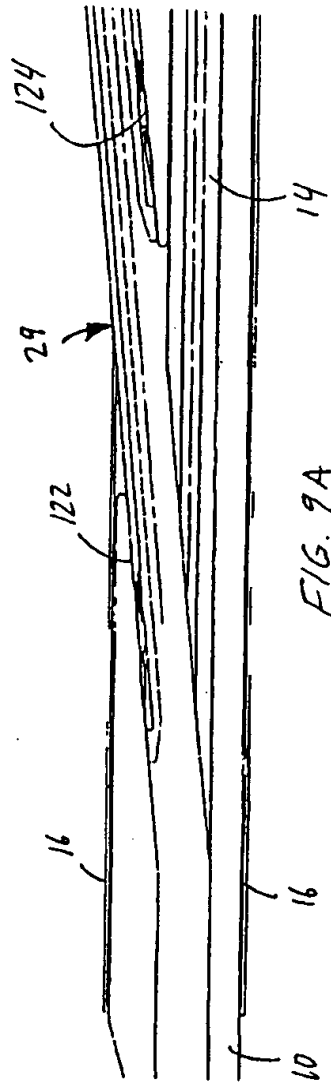
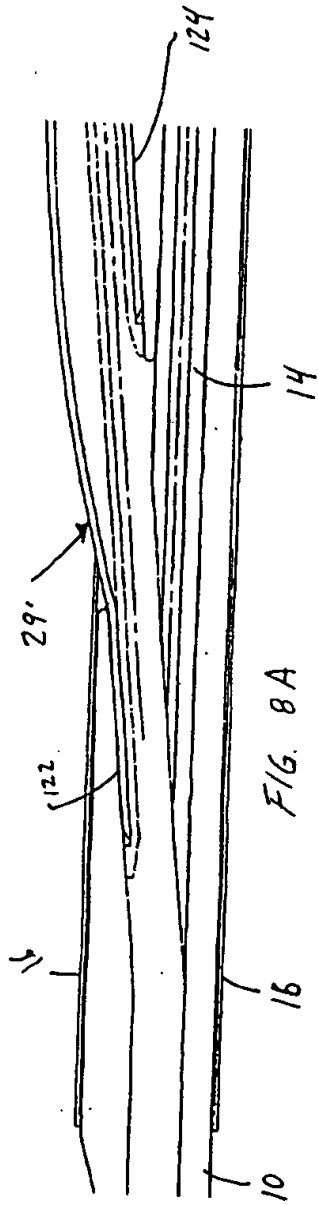

FIG. 5B



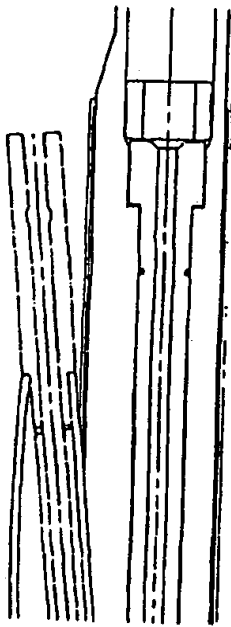

FIG. 8B

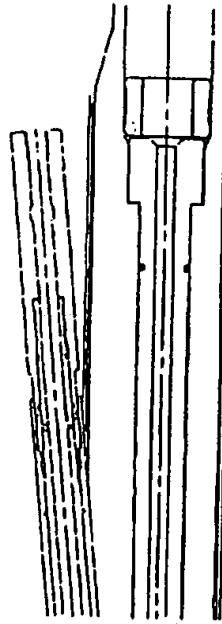

FIG. 9B

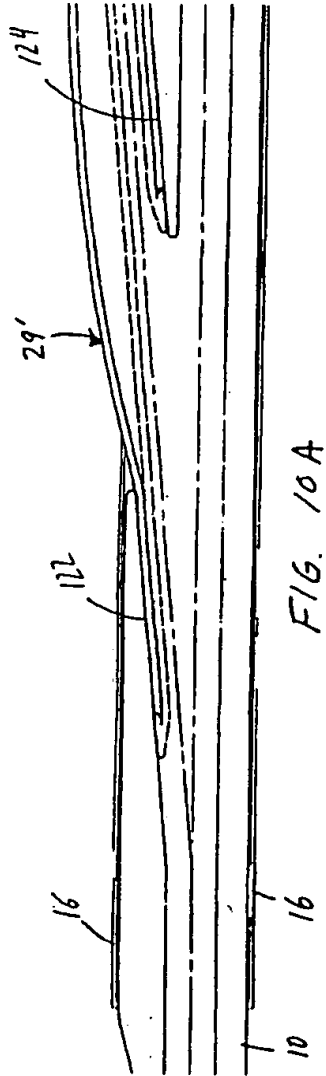

FIG. 10A

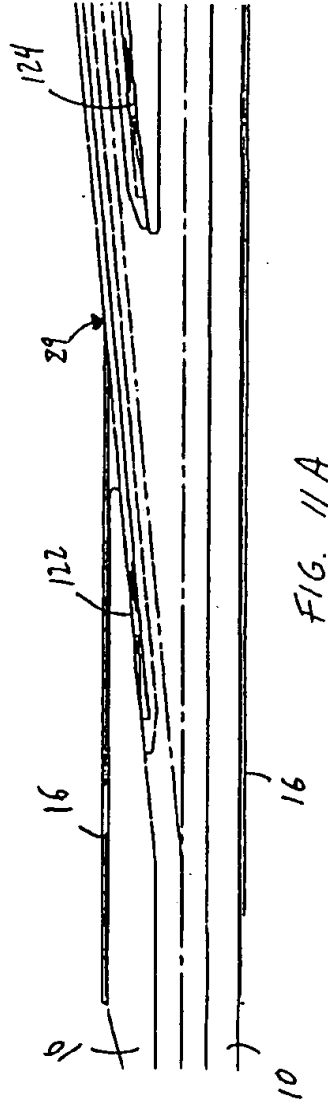

FIG. 11A

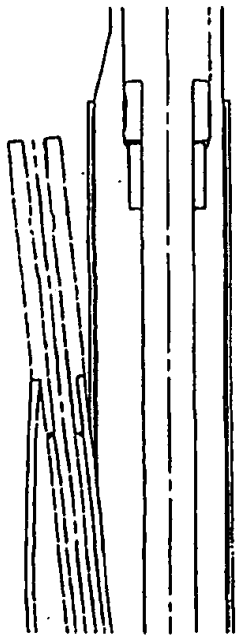

FIG. 10B

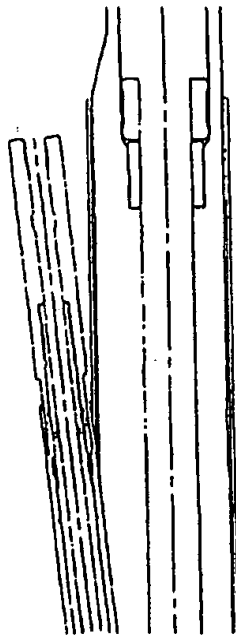
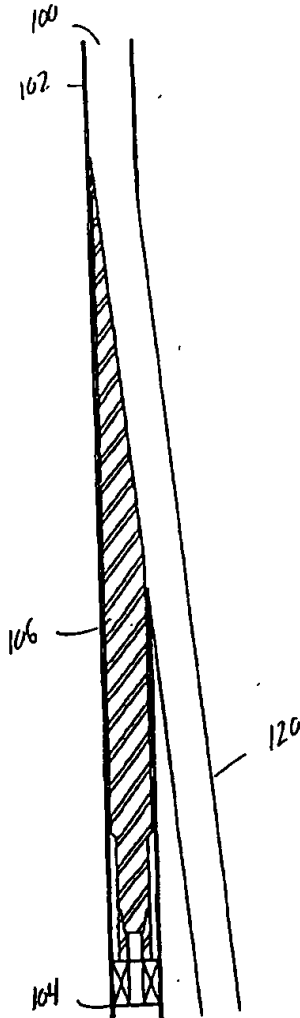

FIG. 11B

9/20

Fig. 12



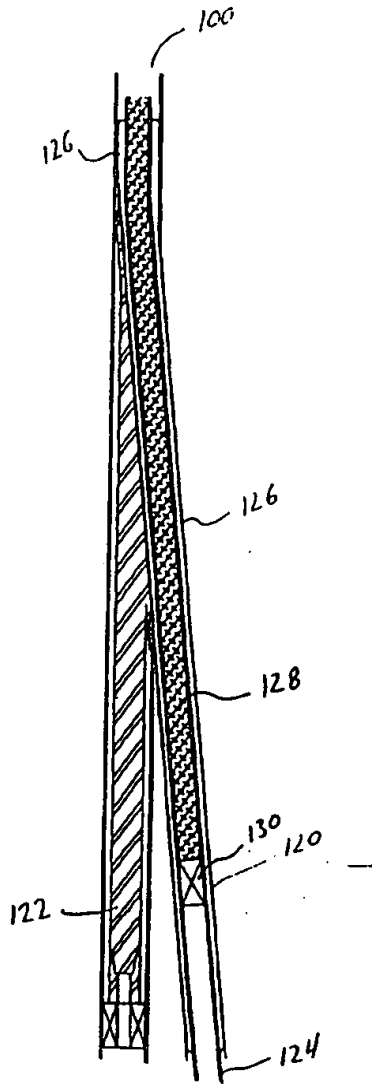

FIG. 13

11/20

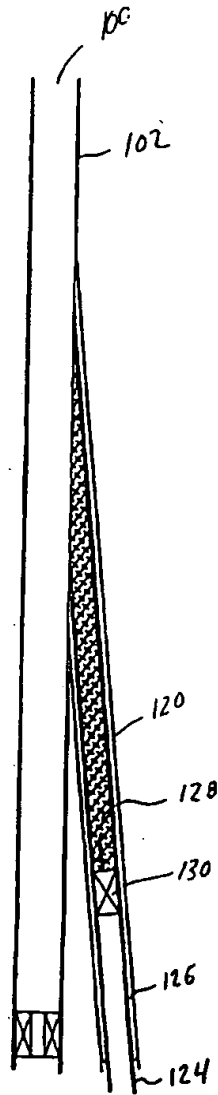

FIG. 14

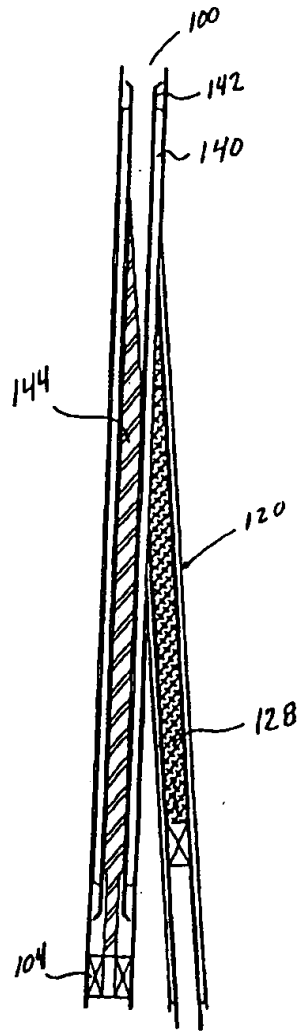

FIG. 15

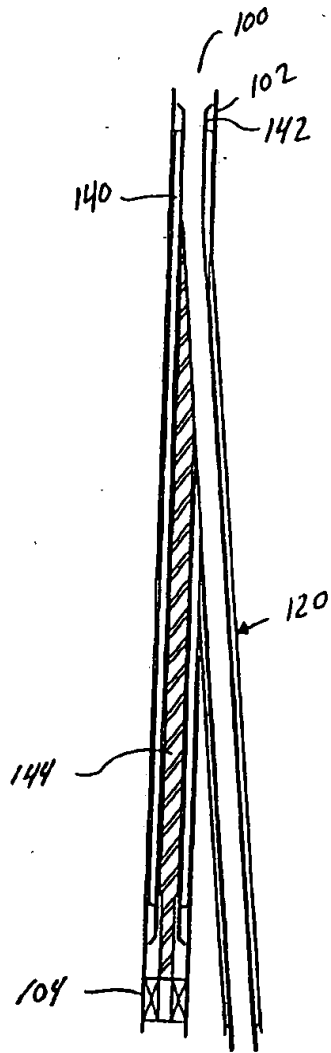

FIG. 16

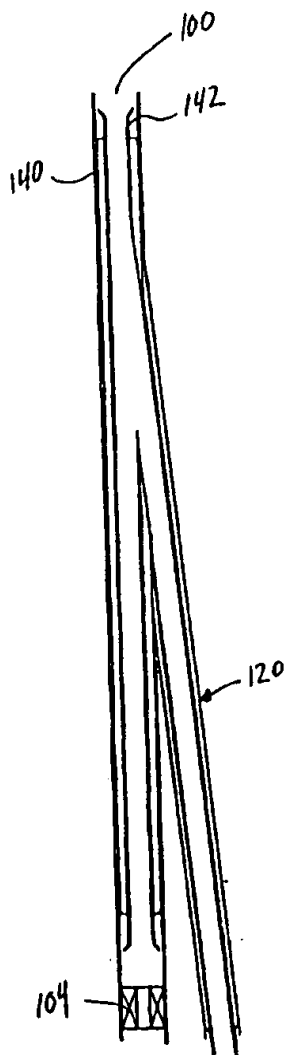

FIG. 17

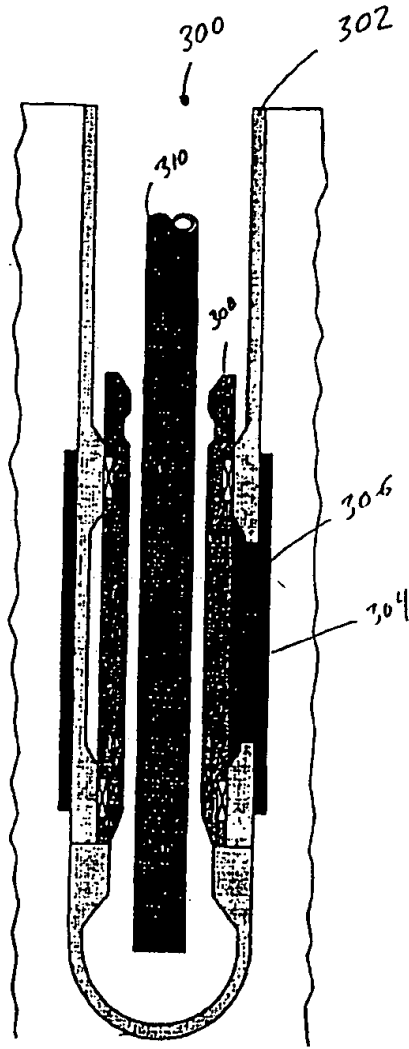

FIG. 18

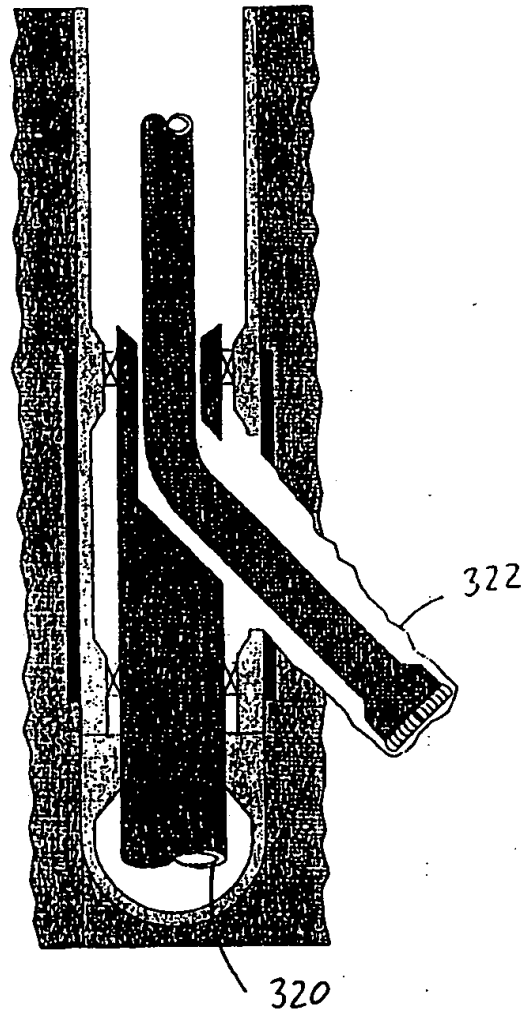

FIG. 19

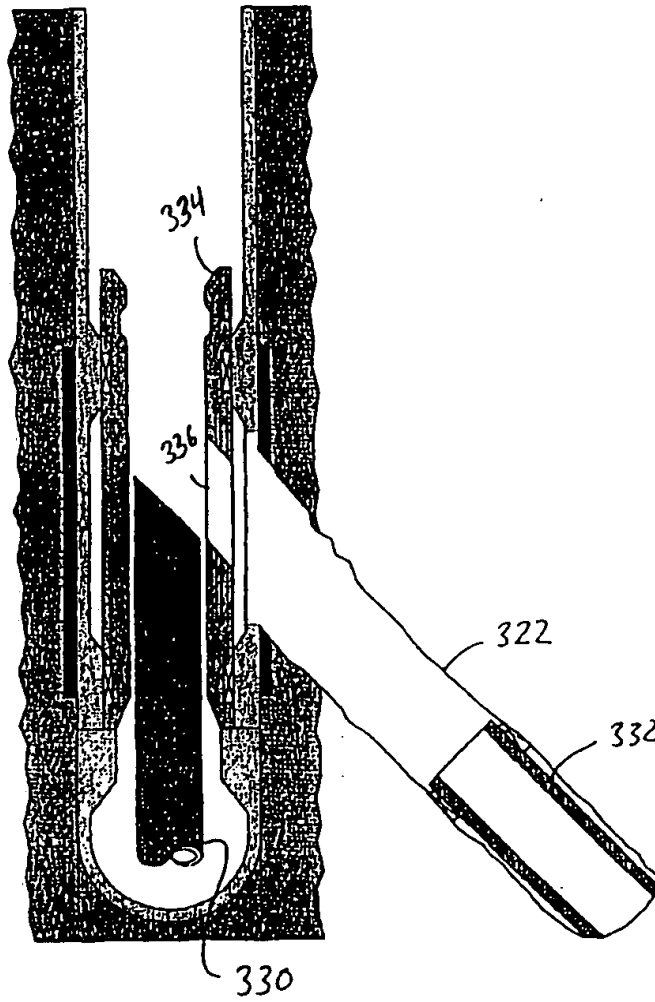

FIG. 20

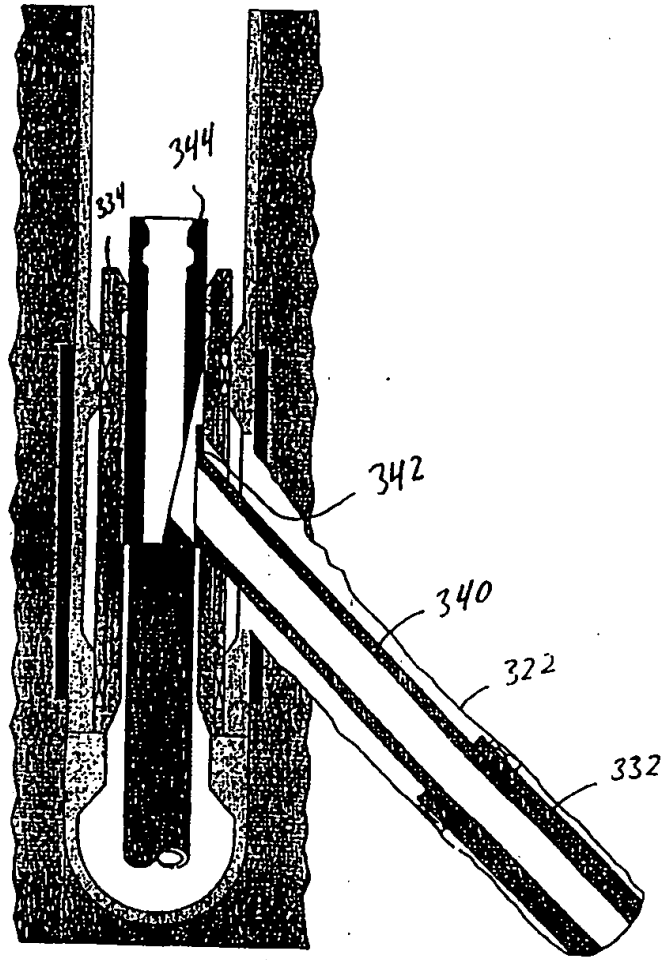

FIG. 2.1

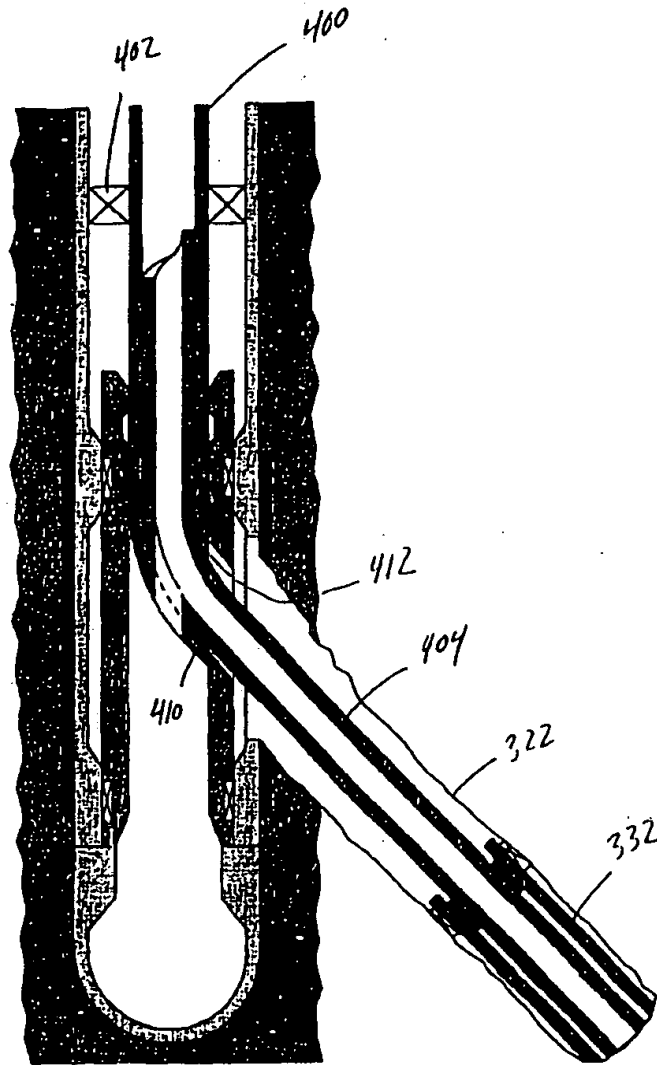

FIG. 22

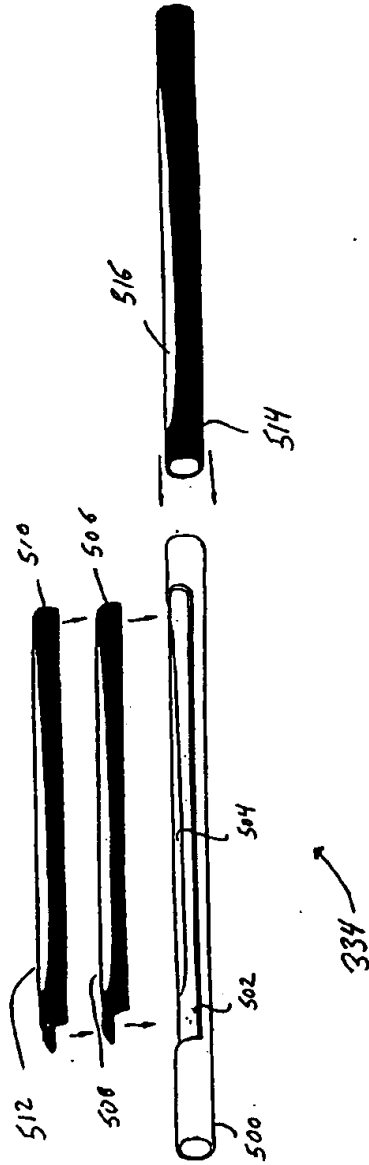

FIG. 23